

McGill

C e n t r e f o r

Intelligent Machines

CIM Overview

- **Who we are:**
 - **An interdisciplinary research center at McGill University.**
 - **Comprised of members from the School of Computer Science and the Departments of Electrical and Mechanical Engineering.**

CIM Overview

- **Mission:**
 - *To pursue excellence in research and teaching in the field of machine intelligence.*

CIM Overview

- **Research Areas**
 - Perception
 - Robotics
 - Systems and Control
 - Person-Machine Communication

Artificial Perception

- James Clark
- Gregory Dudek
- Frank Ferrie
- Martin Levine
- Kaleem Siddiqi

James J. Clark

- **Visual Motor Systems**
- **Active Vision**
- **VLSI Smart Sensors**



Greg Dudek

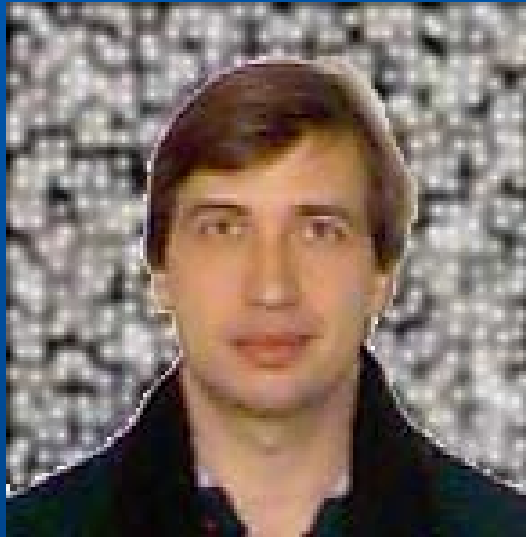

- Perception for Mobile Robotics
- Augmented Reality

Frank Ferrie

- **Autonomous Exploration**
- **Visual Inference**
- **Early Vision**



Artificial Perception

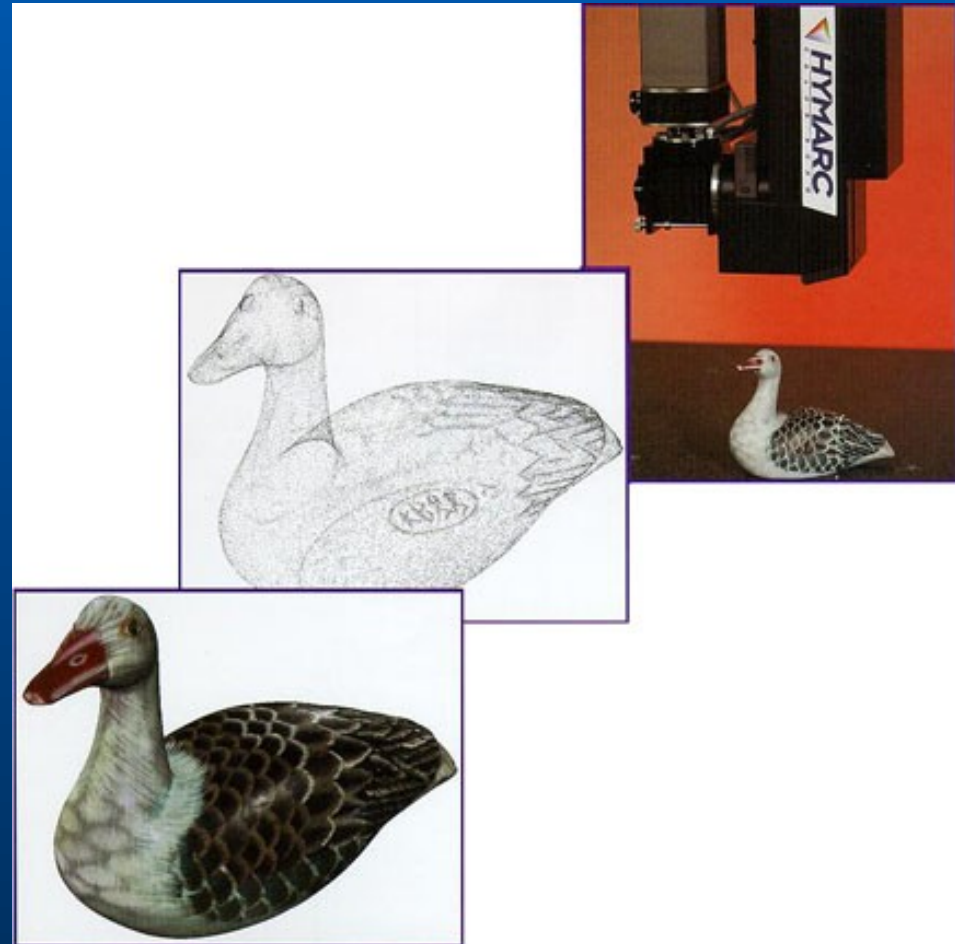

Martin D. Levine

- **Content-Based Image Retrieval**
- **Face Recognition**
- **Car Verification**

Kaleem Siddiqi



- **Computer Vision**
- **Image Processing**
- **Psychophysics**

Intelligent Robot Research

- **Jorge Angeles**
- **Martin Buehler**
- **Luca Cortelezzi**
- **Vincent Hayward**
- **Venkat Krovi**
- **Arun Misra**
- **Paul Zsombor-Murray**

Jorge Angeles



Analysis, synthesis, and optimization of mechanical systems

- CAD/CAM integration
- Geometric modeling
- Multibody dynamics
- Robot design and control
- Theory of kinematic chains

Speed-o-Cam

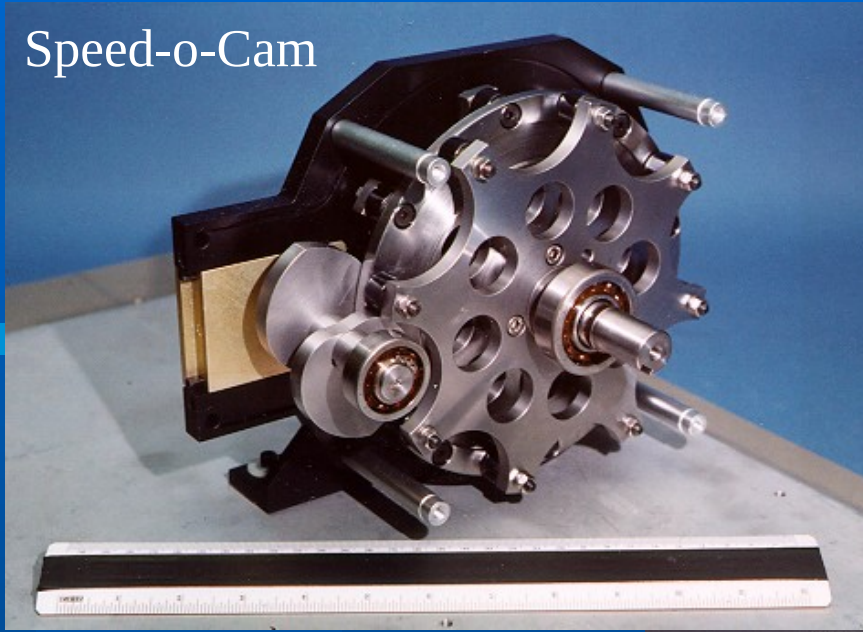

Robot Design

Speed Reducer

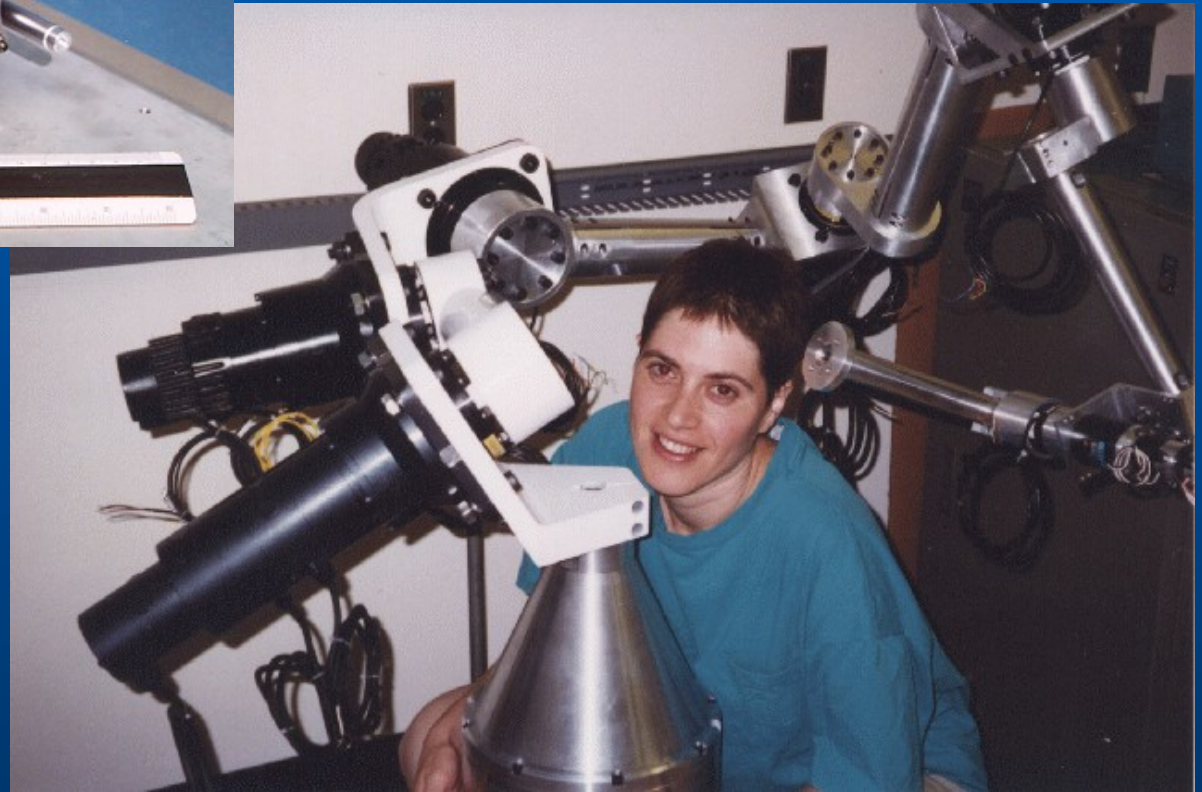

Rediestro-2: Designed for the Canadian Space Agency
COBRA: Application with Bombardier (w. Misra)

Martin Buehler

Robot locomotion

- **Dynamically stable legged locomotion**
- **Design and control of walking, climbing and running robots**
- **Teleoperation and autonomous operation of remote systems**
- **Control of direct drive motors and robots**

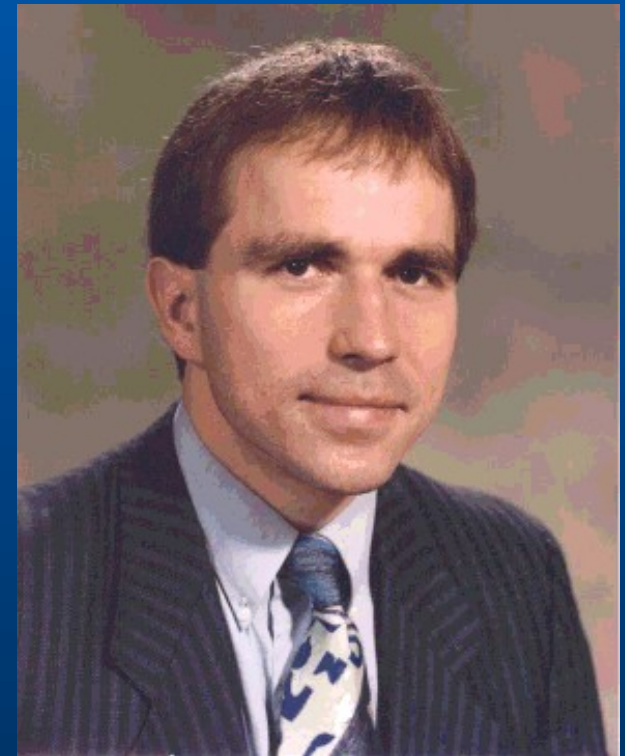

Running

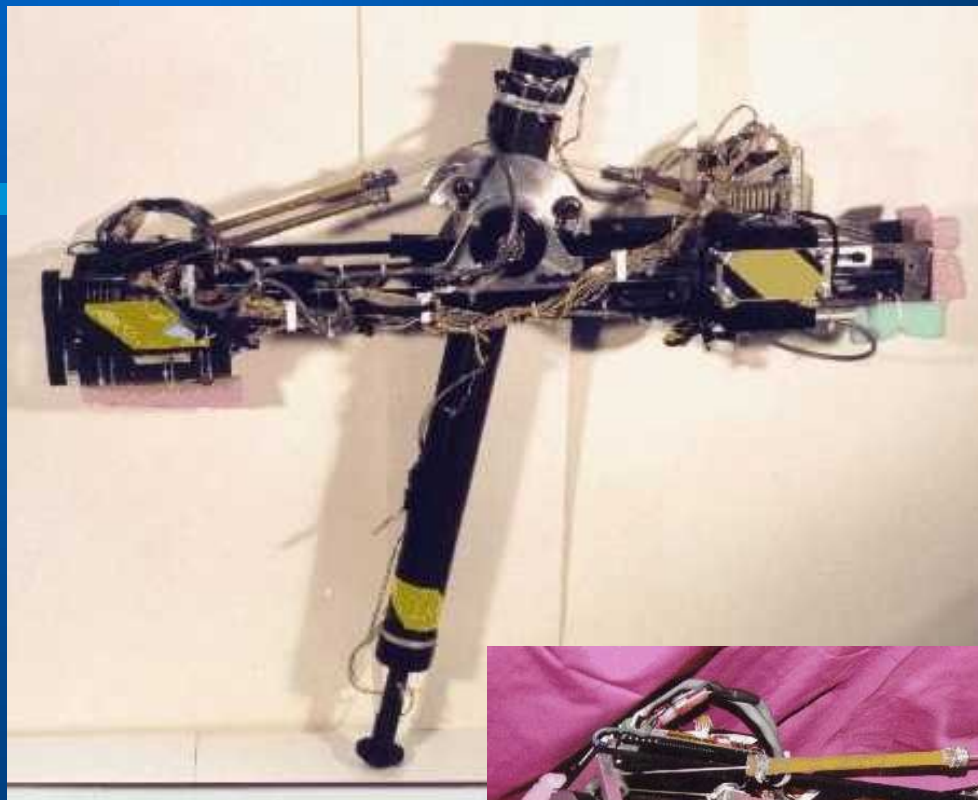

Passive
Dynamics

Walking, Climbing



Luca Cortelezzi

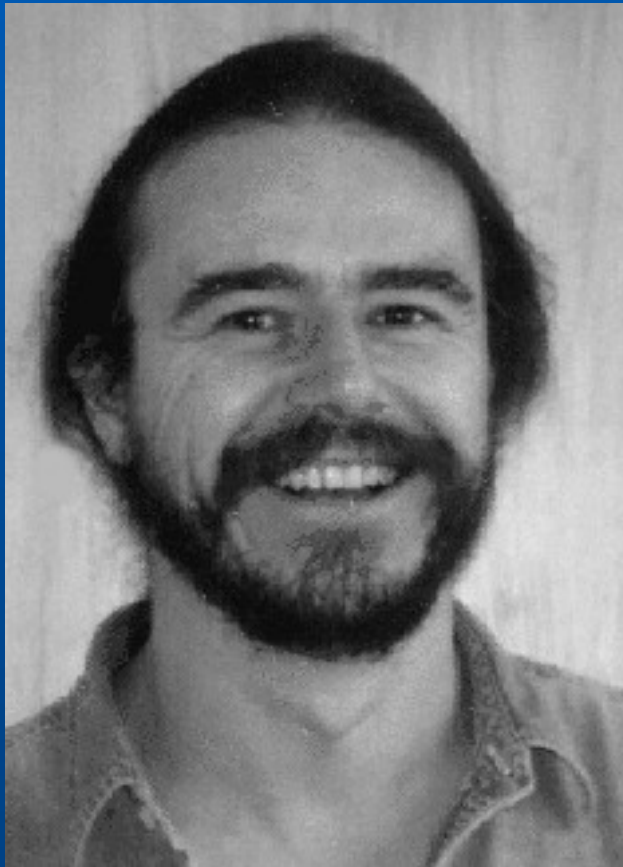

- **Control of unsteady fluid flows**
- **Computational fluid dynamics**
- **Mathematical modeling**
- **Dynamical systems**
- **Control theory.**

Vincent Hayward



Robotics

- **Actuators: design and control**

Haptic Interfaces

- **Device design and control,**
- **Rendering and simulation,**
- **Perceptual Issues,**
- **Applications to medicine, rehabilitation and music**

Actuators

Shape Memory Alloys

Redundant Joint Actuation

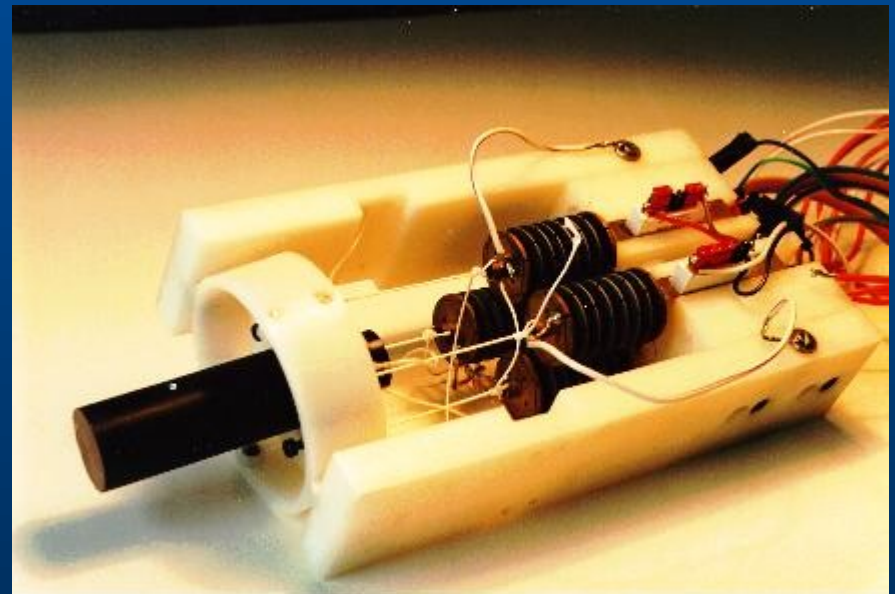
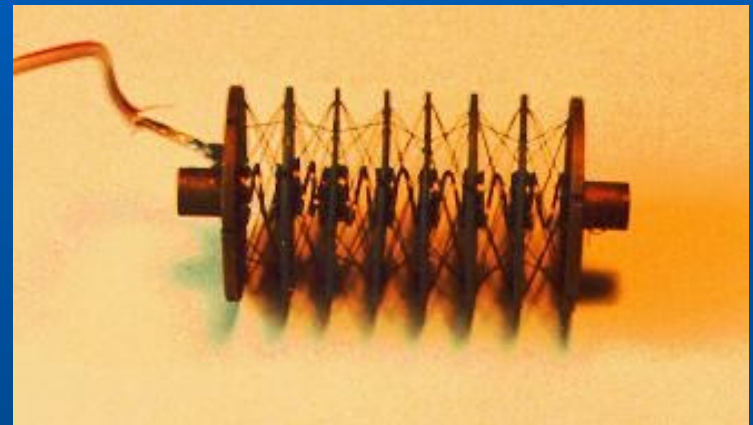
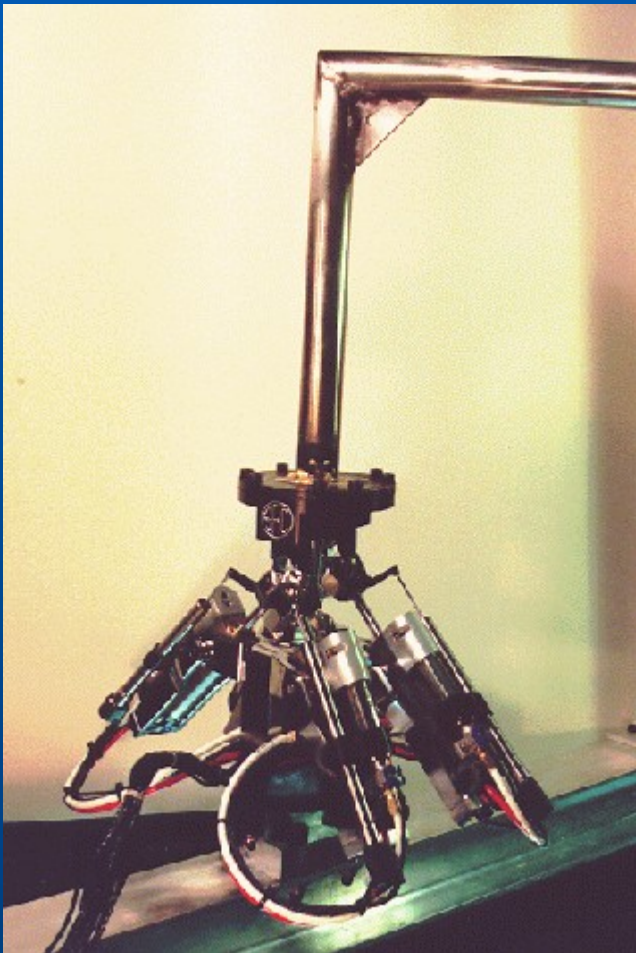

Venkat Krovi

- **Mechanical and mechatronic systems**
- **Design, modeling, control, and prototyping**
- **Rapid virtual and physical prototyping**
- **Human user customization**

Arun Misra

Dynamics and control of space systems

- Flexible multibody dynamics
- Space robotics
- Tethered space systems
- Structural dynamics



Smart structures (CSA)

Manipulator-assisted
capture of satellites

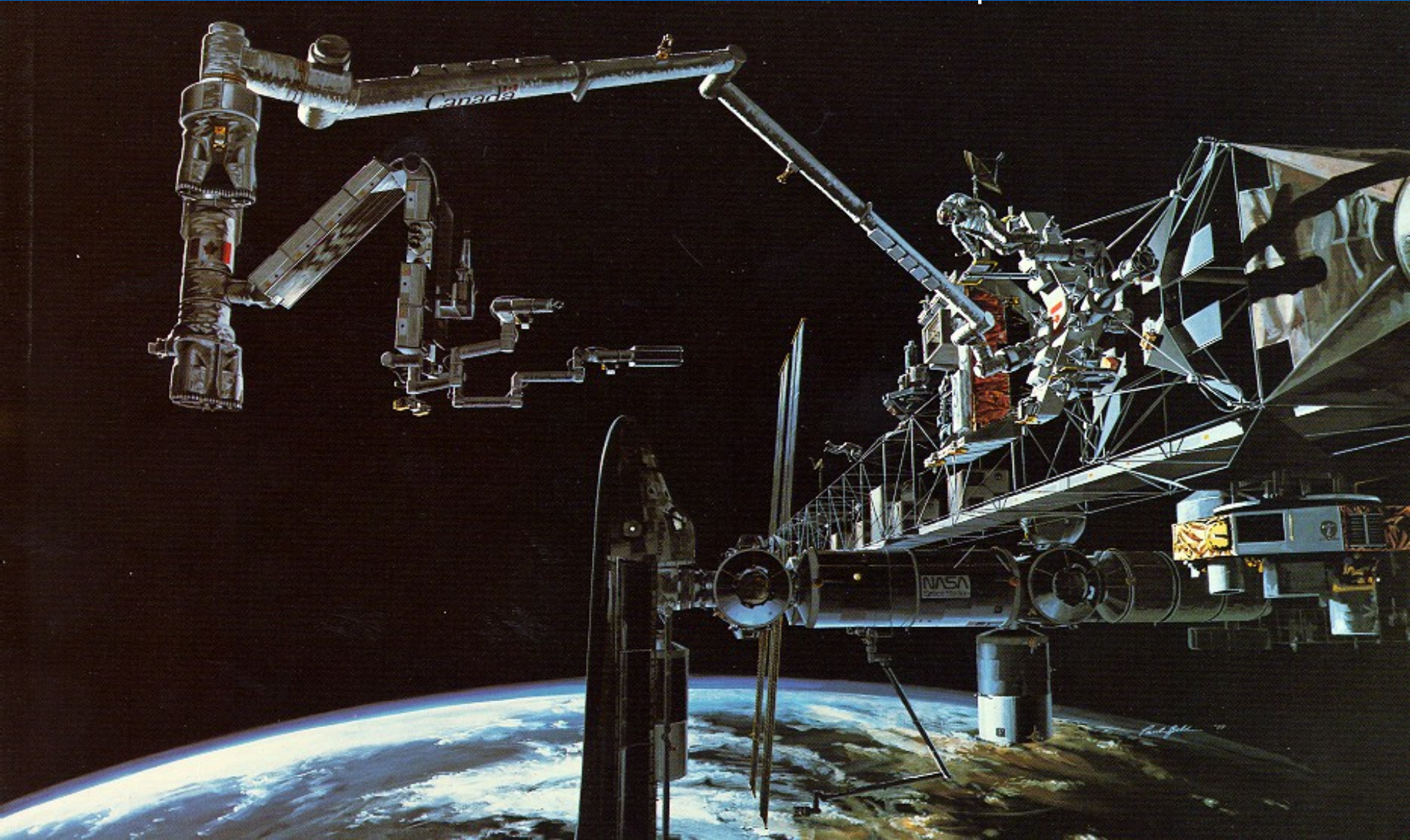

Object-oriented modeling and simulation of
flexible multibody dynamics (CAE)

Paul Zsombor-Murray



Kinematic Geometry

- Design and analysis of motion of articulated multi-rigid-body mechanisms and manipulators
- Parallel mechanisms
- Theoretical kinematics
- Computational kinematic geometry

Double Tetrahedral Mechanism

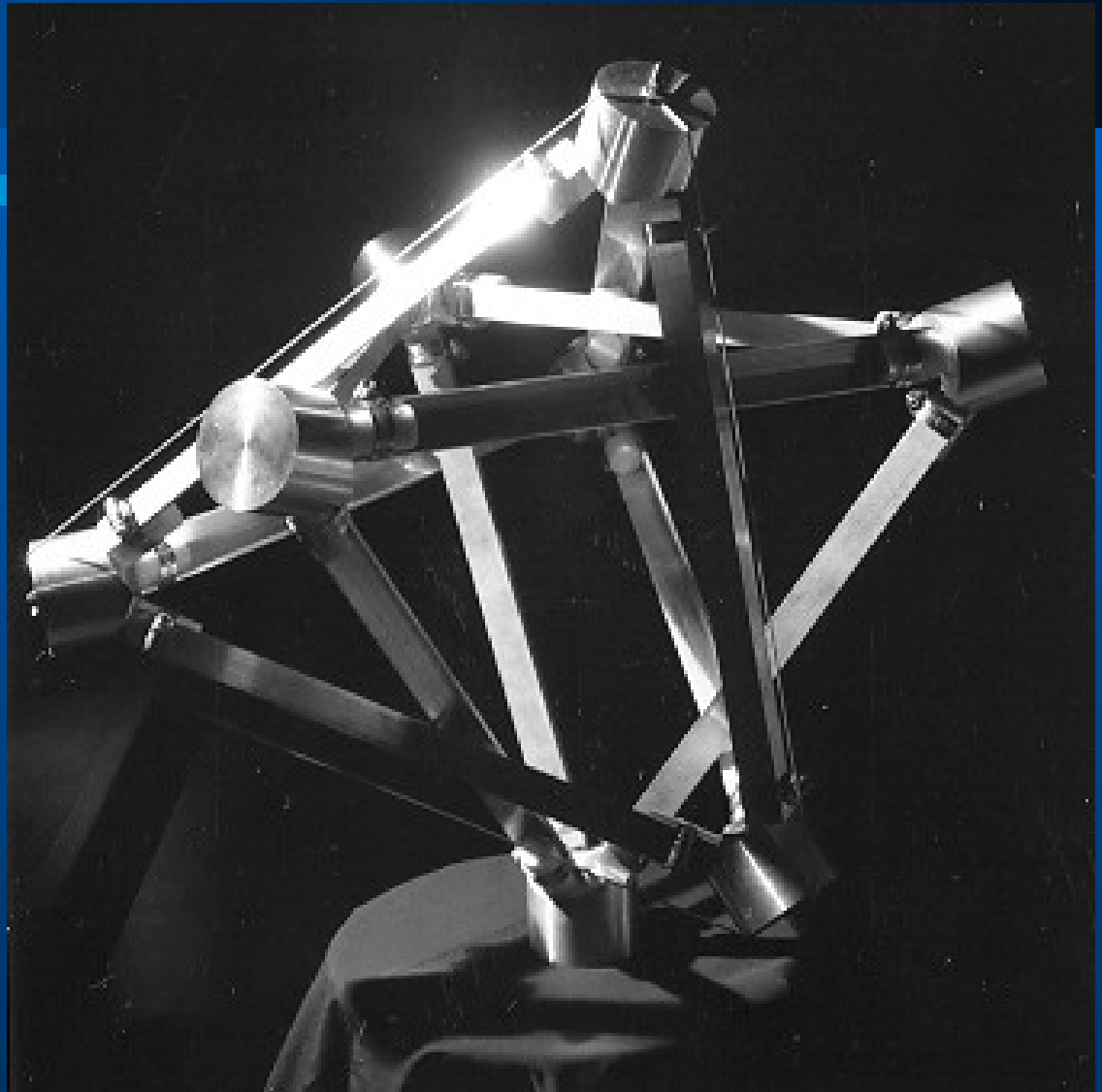

Systems and Control Theory

- **Pierre Belanger**
- **Benoit Boulet**
- **Peter Caines**
- **Charalambos Charalambous**
- **Hannah Michalska**

Optimal Estimation of Object Position and Velocity using Visual Input (K. Benameur Ph.D)

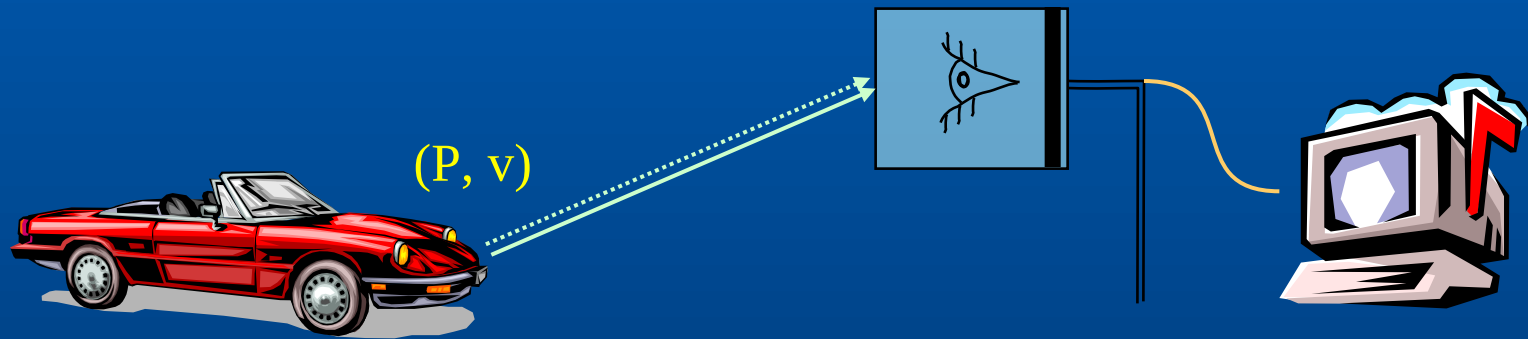

- Using Kalman filtering and control of camera motion to optimize the estimation of P and v

Hierarchical Hybrid Control Theory

- Discrete Event Dynamical Systems (G. Shen, Ph.D, P.Hubbard, Ph.D)

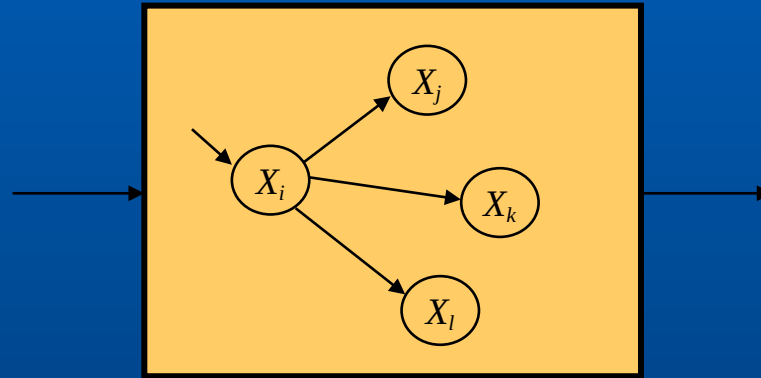

- Hybrid Systems (Ekaterina Lemch)

CONTINUOUS

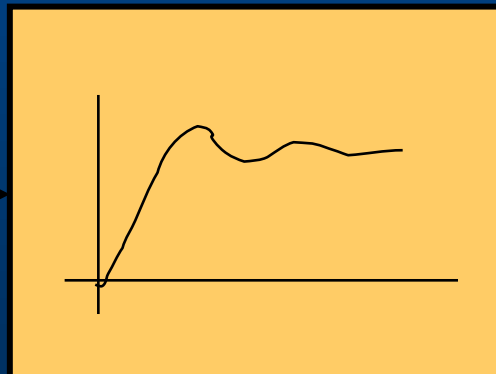

DISCRETE EVENT

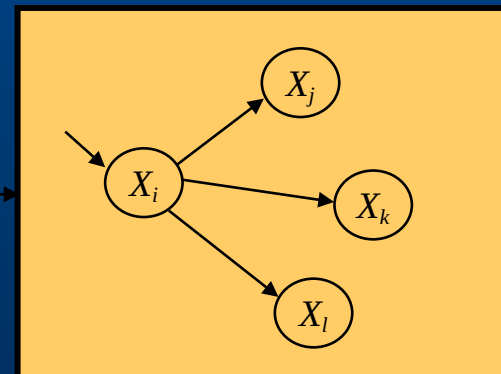

G.E. Appliance Example: Washer and Cam Disk Operation

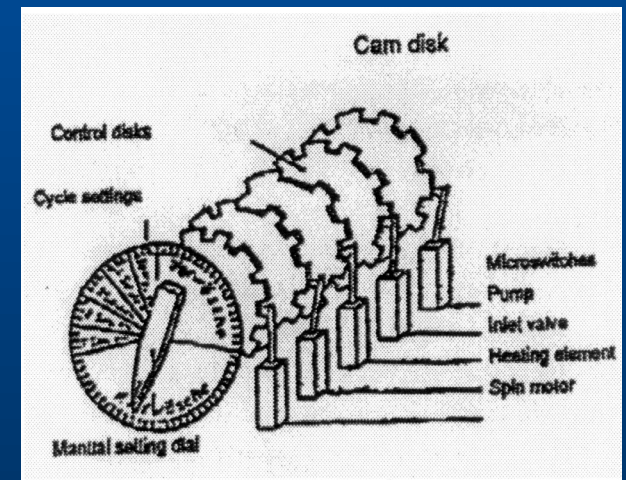
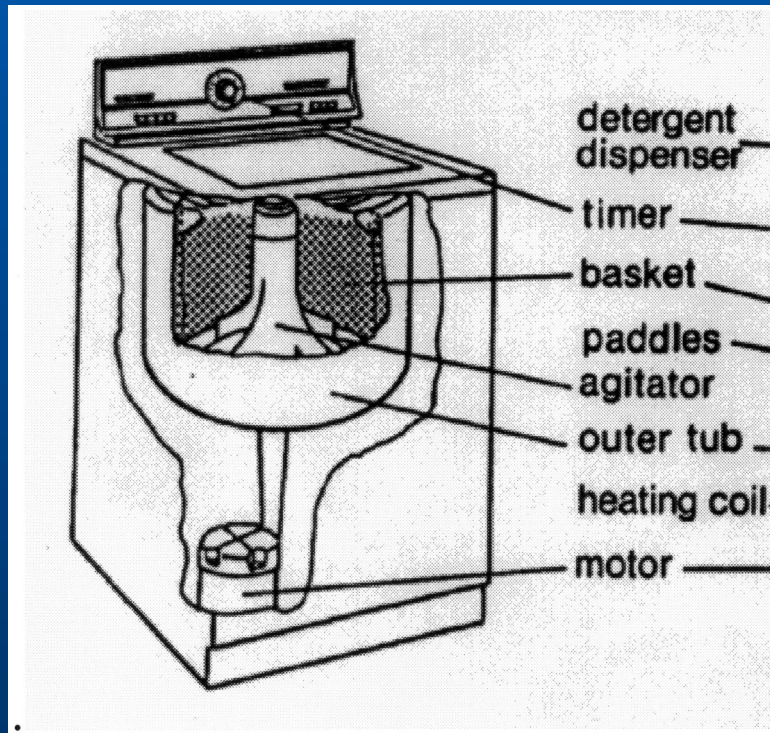

Mobile Robot Example: Floor Layout and Abstract Model

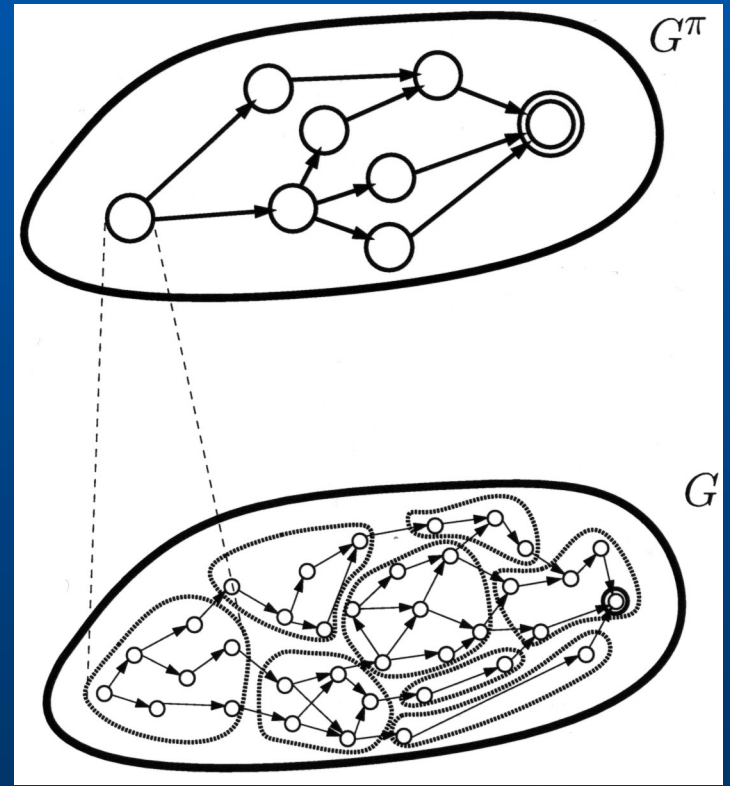
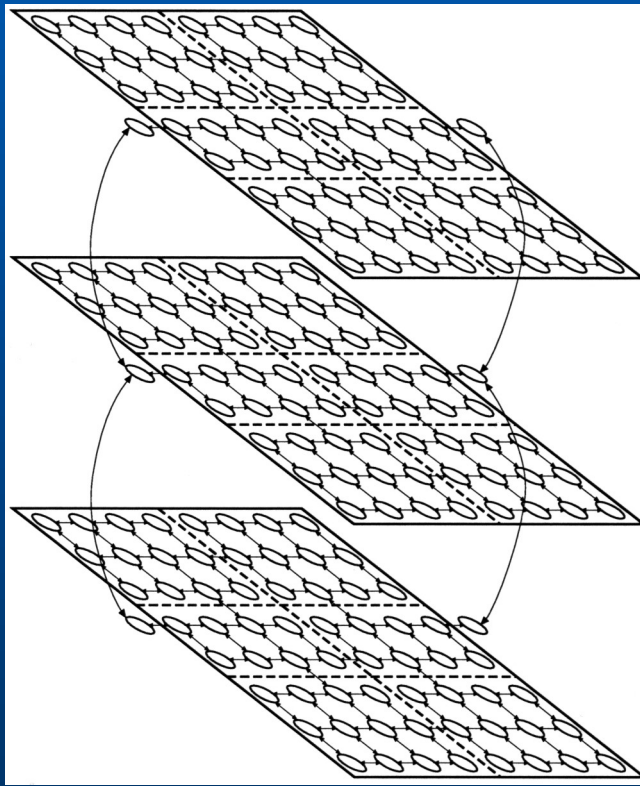

1) Stochastic Processes in Engineering and Mathematical Finance

- Stochastic Control
- Filtering
- Identification

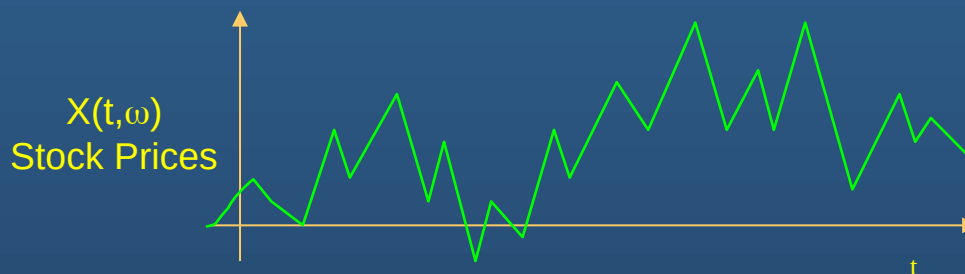

Models: Electronic Noise, Communication Channel Noise

Stock Exchange Prices
Black-Scholes models

- Wireless Telecommunication Networks: Modeling and Control

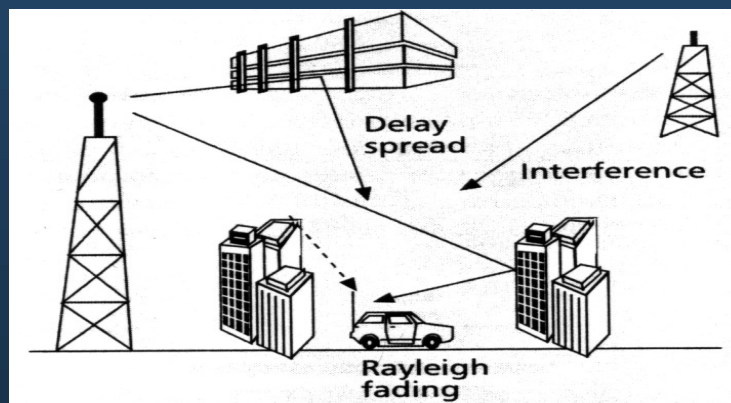

2) H^∞ Controller Synthesis via Network Synthesis

(N. Menemenlis Ph.D)

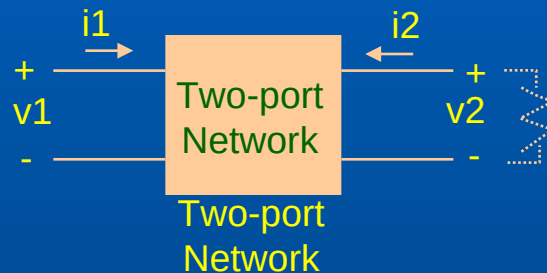

Given input-output characteristics
Synthesize a network

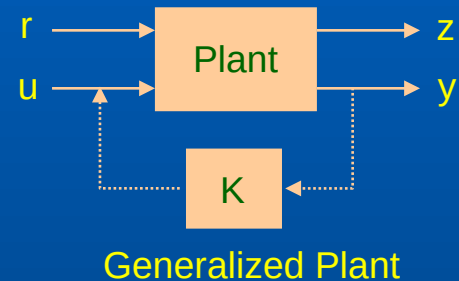

Given desired response
Synthesize a controller K

- Applications in Power Systems

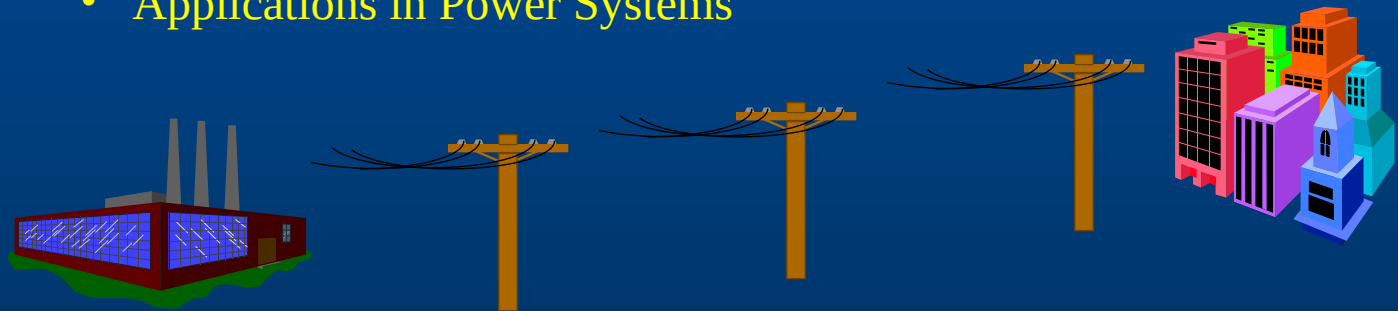

Reliable Power Transmission, High Quality of Power

Control of Nonholonomic Systems

- M. A. Torres Torriti, Ph.D.
- B. Wang, Ph.D.
- K. Kabiri, Ph.D.
- M-C. Lu, M.Eng.



Hannah Michalska

Representative of First Problem Class

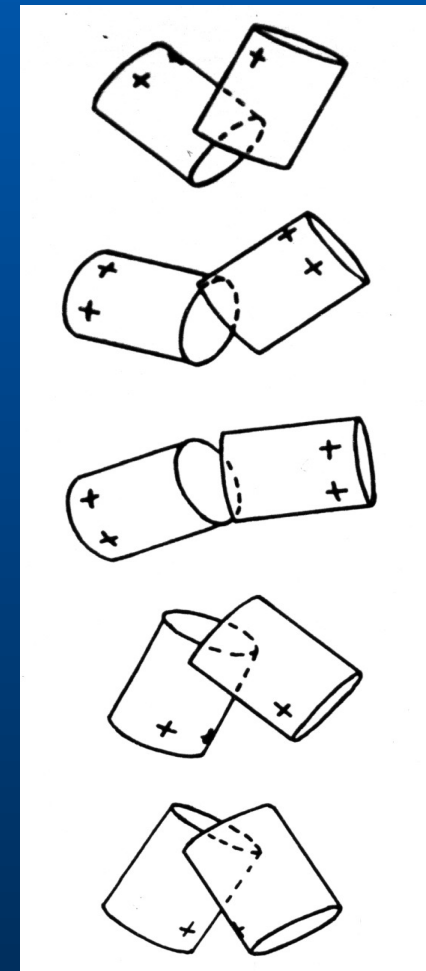
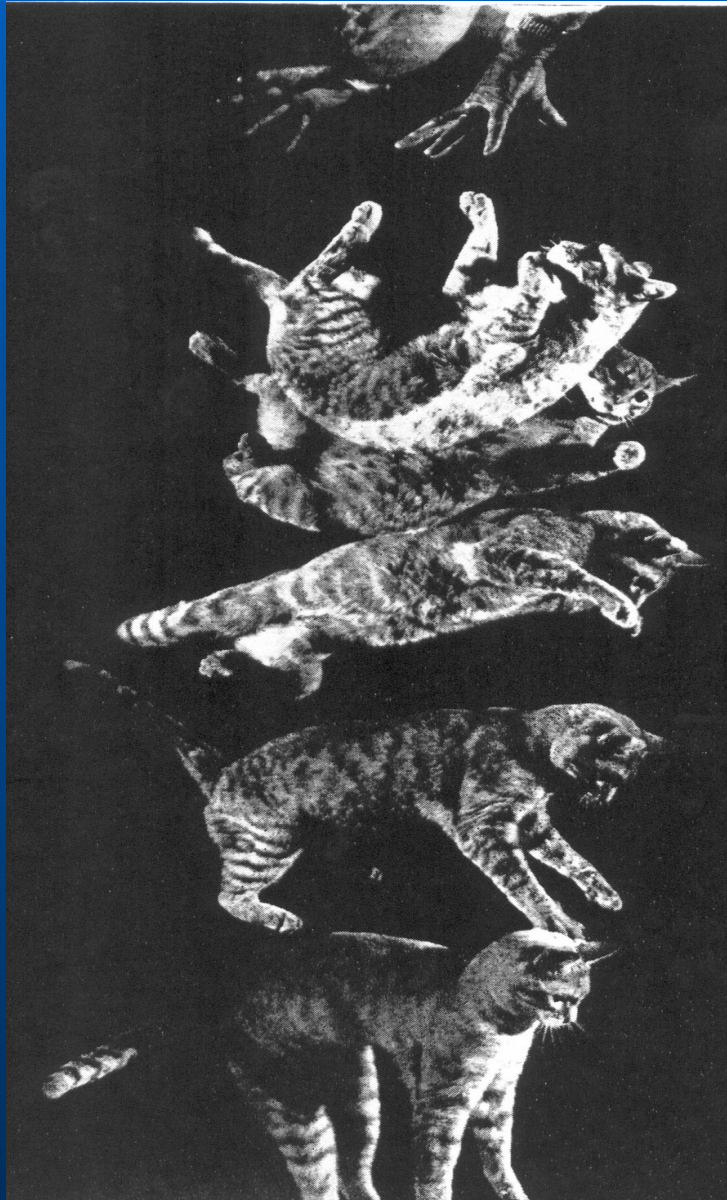

Useful Control Problems of the First Class



Aircraft

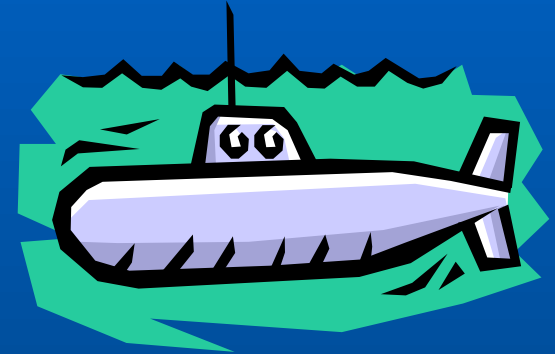

Submarine

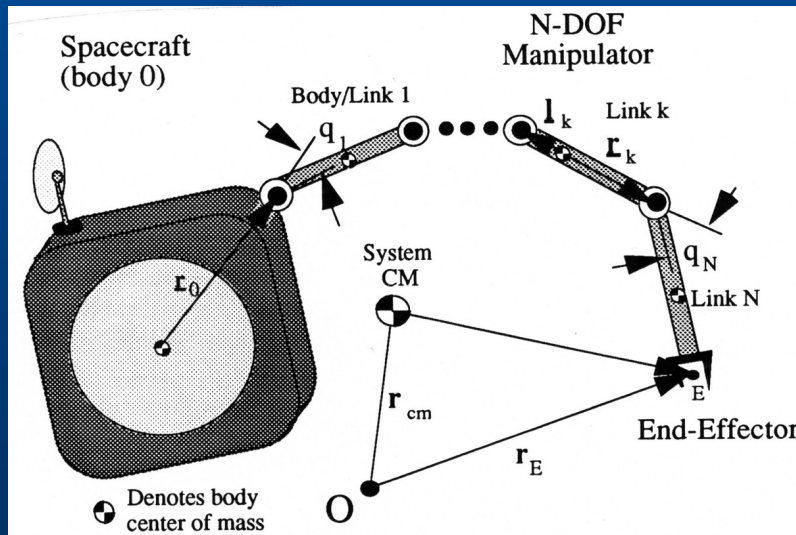

Spatial free-floating manipulator

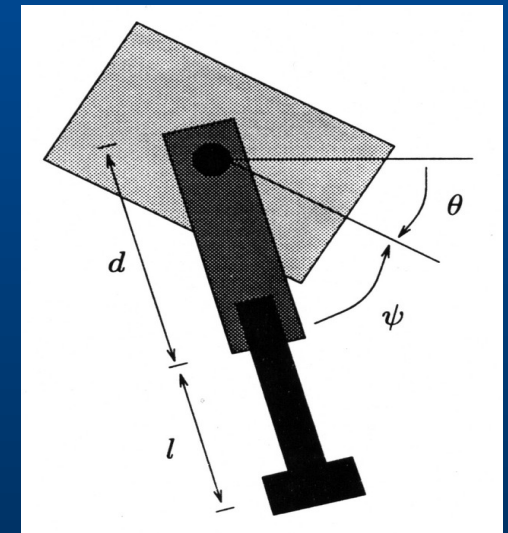

Hopping robot

Hannah Michalska

Useful Control Problems of the Second Class

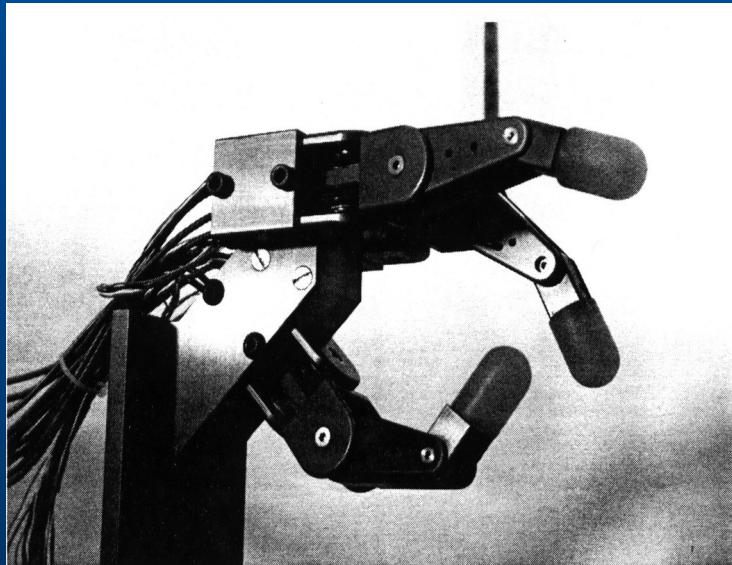
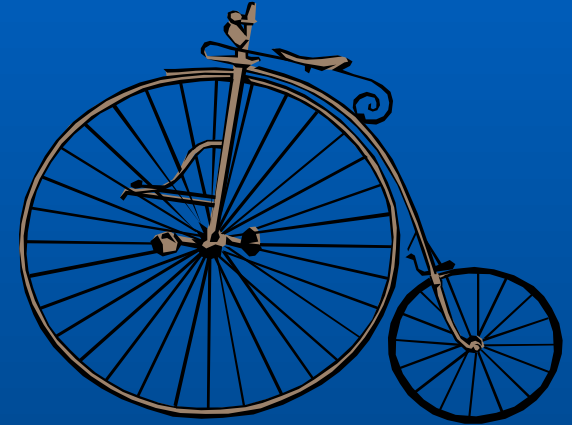
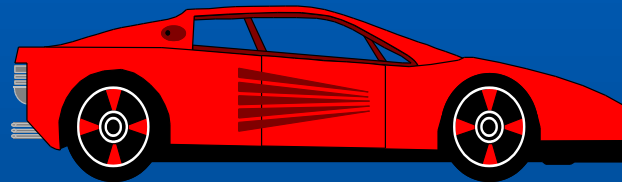

Hannah Michalska

Useful Control Problems of the Second Class

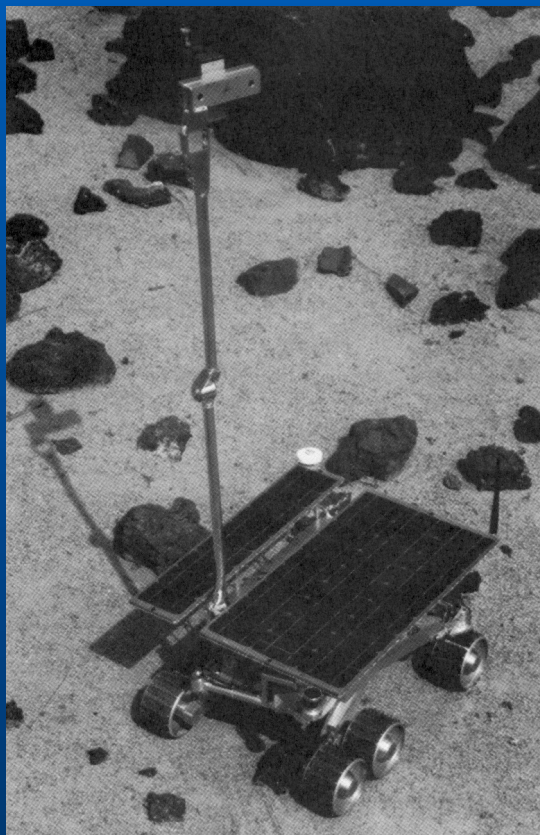

George Zames (1934-1997)

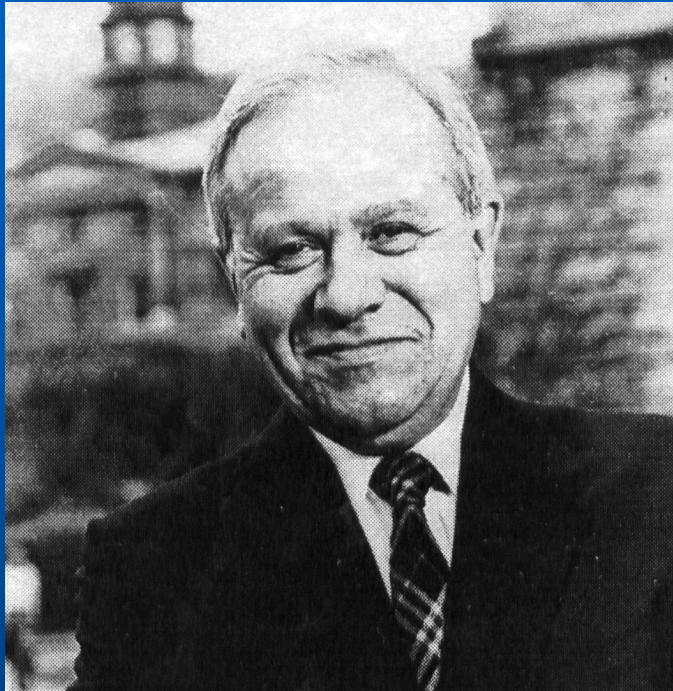

Recipient of the Killam Prize 1996

Ph. D. students: Michael Glaum
Seddick Djouadi
(supervised by C.D. Charalambous)

- Some Applications of Prof. Zames' contributions:
 - improved car suspension
 - noise attenuation in vehicles

Human Computer Interaction

- **James Clark**
- **Jeremy Cooperstock**
- **Vincent Hayward**

James J. Clark

- **model human attention to predict where user is looking in a display**
 - guide relevant placement of information
 - use to draw attention to desired location



Jeremy Cooperstock



- Intelligent environments
- Ubiquitous computing
- Multimodal interfaces
- Adaptive and learning systems
- Media spaces
- Videoconference technology
- Multi-agent systems

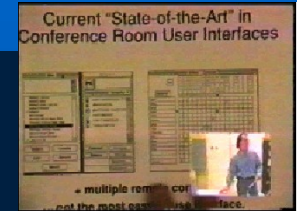

Reactive Room

- fully functional videoconference room
- devices react to human activity
- no explicit interaction with computer



Shared Reality Environment

- **three-screen rear projection enclosure with multi-channel audio**
- **several such rooms networked together**
- **support collaborative human activities**
 - distributed musical performance
 - high fidelity tele-education
 - remote medical diagnosis

Vincent Hayward



Haptic Interfaces

- **real-time finite element simulation**
- **haptic simulation of friction**
- **device for display of tactile information**

Applications

- teleoperation
- medicine
 - surgery, rehabilitation, simulation, enhanced medical image exploration
- animation, CAD
- music



The Pantograph

- simple desktop device
- applied to:
 - rehabilitation for the visually handicapped
 - operator assistance in micro-gravity



Commercialized by
Haptic Technologies

Freedom-6

- advanced 6 dof device
- supports the simulation of a variety of basic surgical instruments



Commercialized by
MPB Technologies Inc.